

# Monocular Vision Leads to a Dissociation between Grip Force and Grip Aperture Scaling during Reach-to-Grasp Movements

Stephen R. Jackson,<sup>1,3</sup> Roger Newport,<sup>1</sup> and Andrew Shaw<sup>2</sup>

<sup>1</sup>School of Psychology  
University of Nottingham  
Nottingham NG7 2RD  
United Kingdom

<sup>2</sup>School of Psychology  
University of Wales, Bangor  
Gwynedd LL57 2DG  
United Kingdom

## Summary

It has been argued that visual perception and the visual control of action depend upon functionally distinct and anatomically separable brain systems [1–3]. Electrophysiological [4] evidence indicates that binocular vision may be particularly important for the visuomotor processing within the posterior parietal cortex, and neuropsychological [5, 6] and psychophysical [7–11] studies confirm that binocular vision is crucial for the accurate planning and control of prehension movements. An unresolved issue concerns the consequences for visuomotor processing of removing binocular vision. By one account, monocular viewing leads to reliance upon pictorial visual cues to calibrate grasping [6] and results in disruption to normal size-constancy mechanisms [6, 7]. This proposal is based on the finding that maximum grip apertures are reduced with monocular vision. By a second account, monocular viewing results in the loss of binocular visual cues and leads to strategic changes in visuomotor processing by way of altered safety margins [9–11]. This proposal is based on the finding that maximum grip apertures are increased with monocular vision. We measured both grip aperture and grip force during prehension movements executed with binocular and monocular viewing. We demonstrate that each of the above accounts may be correct and can be observed within the same task. Specifically, we show that, while grip apertures increase with monocular vision, consistent with altered visuomotor safety margins, maximum grip force is nevertheless reduced, consistent with a misperception of object size. These results are related to differences in visual processing required for calibrating grip aperture and grip force during reaching.

## Results and Discussion

As noted above, previous psychophysical studies have produced contradictory findings with respect to the effects of monocular viewing on the scaling of maximum grip aperture during prehension [6–11]. The aim of the current study was therefore to further investigate the

effects of monocular vision on the planning and execution of unconstrained reach-to-grasp movements. Specifically, we wished to reexamine the consequences of removing binocular visual cues for the calibration of the grasp component of the reach-to-grasp movement.

In a previous study, we demonstrated that grip aperture scaling and grip force scaling could be dissociated from one another with respect to the effects of pictorial visual cues [12]. In that study, participants reached to cylindrical target objects presented against the converging or diverging ends of the Ponzo visual illusion. Perspective cues within this illusory figure produce a perceived increase in the size of objects viewed against the converging lines within the figure. Grip apertures were recorded using an optoelectronic measuring device, and grip force was recorded by embedding a force transducer within the cylindrical objects used as targets. The results of this study indicated that grip aperture scaling was unaffected by the presence of the visual illusion. In contrast, maximum grip force increased significantly when the target object was presented against the converging ends of the illusory figure, i.e., when there was an illusory increase in the perceived size of the target object. We suggested that the primary task of the visuomotor mechanisms underlying hand kinematics might be to determine where to position the digits on the target object so as to achieve a stable grasp. Furthermore, we suggested that this visual analysis need not necessarily require a complete description of the object, including object classification or identification. In contrast, object knowledge/perception may be critical to the anticipatory control of grip force. This may include general knowledge about objects, e.g., that objects of a given size that are smooth, shiny, and metallic are typically heavy, as well as specific knowledge based upon prior experience with particular objects. A dissociation between grip force scaling and grip aperture scaling is therefore predicted in circumstances in which individuals make use of perceptual mechanisms, specifically pictorial visual cues, to calibrate movements.

We adapted the above method to investigate the effects of removing binocular visual cues on grip aperture and grip force scaling. Figure 1 illustrates the experimental procedures used. Participants executed reach-to-grasp movements from a fixed starting position toward target objects presented randomly at five different positions within the workspace (Figure 1A). Target objects were formed by placing two PVC cylinders onto the shafts of a force transducer to produce a single solid object. Targets were presented randomly at one of four orientations with respect to the body's sagittal axis (Figure 1B). Binocular viewing and monocular viewing trials were blocked, the order of the blocks being counterbalanced for each subject using an ABBA design. In monocular viewing trials, vision to the participant's nondominant eye was occluded by means of liquid crystal lenses worn over each eye (see [9] for details). These lenses were normally transparent and were mounted within a

<sup>3</sup>Correspondence: stephen.jackson@nottingham.ac.uk

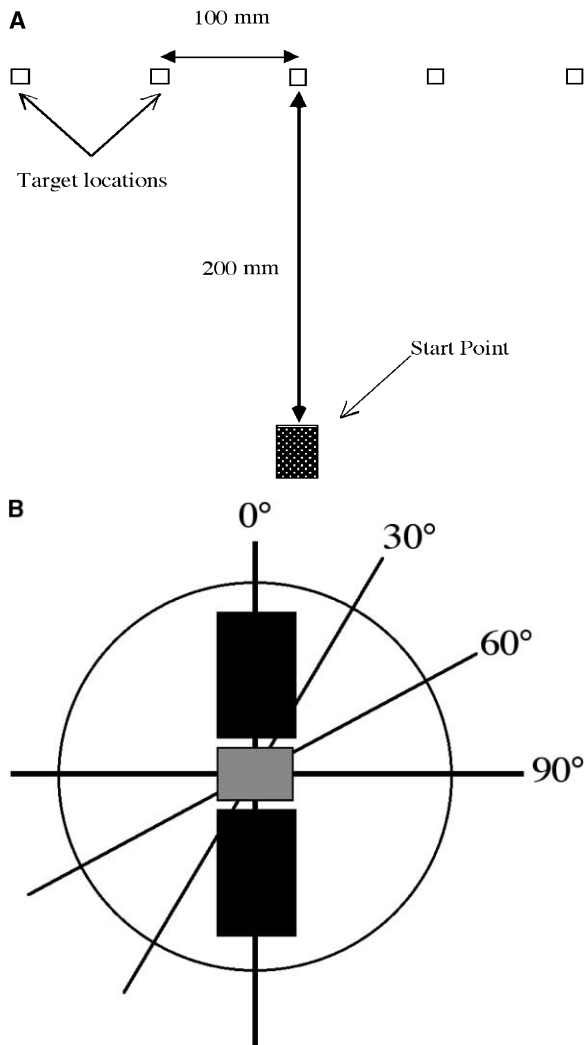

Figure 1. Experimental Apparatus and Design

(A) The dimensions of the experimental apparatus.

At the beginning of each trial, subjects placed their right hand at a fixed start position and, on receipt of an auditory signal, reached out and grasped the target object that was placed at one of five target locations.

(B) The target object measured 25 mm × 68 mm and was formed from two PVC cylinders pushed onto the shafts of a force transducer (Novatech model F250, which was presented at random in one of four orientations). An orientation of 0° corresponds to the long axis of the target object lying parallel to the subject's midsagittal axis, while an orientation of 90° corresponds to the long axis of the target object lying perpendicular to the subject's midsagittal axis.

pair of spectacle frames that were worn throughout the experiment by all participants. In binocular viewing trials, both lenses remained clear throughout the block. In monocular viewing trials, the participant's nondominant eye was occluded throughout the block.

Table 1 contains relevant means for a number of dependent measures that are frequently reported within investigations of reach-to-grasp kinematics [6–12] together with the mean maximum grip force. Inspection of this table confirms that monocular viewing led to statistically significant changes for all dependent vari-

ables. Movement durations (MT) were longer, and peak velocities (PV) were lower when participants were deprived of binocular vision. Furthermore, under conditions of monocular viewing, participants reached their peak movement velocity (TTPV) earlier and spent longer periods of time decelerating (as a percentage of total movement duration, DP%) than in trials in which binocular cues are available. It should be noted that these findings replicate those obtained in previous investigations [7–11].

As reach velocity is reliably scaled to movement amplitude and maximum grip aperture is scaled to object size, Servos and colleagues [7, 8] proposed that participants were underestimating object distance during monocular viewing and, as a consequence, underestimating the size of the target object [7]. In their view, removal of binocular vision led to a disruption of normal size-constancy mechanisms and resulted in the inappropriate calibration of grip aperture [6]. However, the reduction in movement velocity under monocular viewing conditions, which Servos and colleagues take to reflect an underestimation of object distance, can plausibly be interpreted as reflecting a recalibration of visuomotor safety margins so as to maintain consistent levels of accuracy after the removal of binocular visual cues [9–11]. Thus, it is the combination of reduced peak velocity together with reduced grip aperture that provides support for Servos et al.'s [7] proposal, as the “recalibration of visuomotor safety margins” account predicts that grip aperture will increase when visual cues are removed (e.g., stereopsis).

A key aspect of the Servos et al. account is that, in the absence of binocular visual cues, neurologically intact individuals will make use of perceptual mechanisms, specifically pictorial visual cues (e.g., linear perspective, occlusion, texture, shading), to compute movement amplitude and thus the size of the goal object from the uncalibrated retinal image. Important evidence in support of this proposal was obtained in a study of two visual form agnostic patients who each presented with well-documented problems of visual perception but could nevertheless perform visually guided movements with remarkable accuracy under conditions of binocular viewing [6]. Both patients showed a similar impairment under monocular viewing conditions. As the distance of the target object increased, both patients systematically reduced the width of their maximum grip aperture. This effect was not observed in control subjects and is consistent with a loss of size constancy in which the patients perceive objects that are closer to be larger.

Inspection of Table 1 confirms that the mean peak grip aperture for reaches executed with monocular vision was significantly different from that executed when binocular vision was available ( $F[1, 10] = 14.7, p < 0.005$ ). The direction of this difference, however, was the opposite to that predicted by the Servos et al. account. Grip apertures increased under monocular viewing (Figure 2A), as predicted by the “recalibration of visuomotor safety margins” account [9–11]. Mean peak grip force also differed for trials with monocular and binocular vision ( $F[1, 10] = 6.8, p < 0.05$ ). However, contrary to what might be expected from a “recalibration of visuomotor safety margins” account, mean peak grip

Table 1. A Summary of Means for All Dependent Measures under Binocular and Monocular Viewing Conditions Together with the Size of Any Statistical Effect

Measure	Binocular	Monocular	Statistical Effect
MT (ms)	1082 (17)	1234 (22)	$F[1,10] = 25.2, p < 0.0005$
PV (mm/s)	937.9 (12.3)	900.1 (12.6)	$F[1,10] = 12.7, p < 0.005$
TTPV (ms)	335 (4)	343 (4)	$F[1,10] = 6.3, p < 0.05$
DP (%)	67.9 (0.4)	70.7 (0.5)	$F[1,10] = 42.5, p < 0.0001$
MGA (mm)	109.7 (0.5)	112.4 (0.6)	$F[1,10] = 14.7, p < 0.005$
TTMGA (ms)	736 (10)	761 (11)	$F[1,10] = 5.6, p < 0.05$
MGF (N)	0.53 (0.02)	0.48 (0.02)	$F[1,10] = 6.8, p < 0.05$

Standard errors are presented within parentheses.

force actually decreased significantly in monocular viewing trials. It should be noted that the control of grip force shows “anticipatory parameter control” [13]. That is, grip force scaling is anticipatory and predictive. Visual size cues are used, prior to an object breaking contact with the surface on which it is resting (when veridical information about the weight of the object is available via somatosensory cues), to predict the appropriate lev-

els of grip force required to lift the object [13]. As grip force is also reliably and consistently scaled to object size [13], we interpret our finding as evidence that the participants were, consistent with the Servos et al. account, underestimating the size of the target objects when binocular visual cues were removed. It is important to note, however, that maximum grip force could be influenced by reaching kinematics. In the current study, therefore, maximum grip force might be decreased under monocular viewing conditions because movement velocities are reduced. We feel that this explanation is unlikely for two reasons. First, in a previous study that examined grip force scaling in patients recovering from parietal cortex damage [14], we showed that patients recovering from brain injury, who reached substantially more slowly than their healthy age-matched controls, nevertheless produced much larger maximum grip force values than healthy age-matched controls. This demonstrates that slowed reaching movements are not necessarily associated with decreased maximum grip force. Second, when we examined this directly for the current data, we found that the correlation between peak velocity values and maximum grip force values is not statistically significant ( $R = -0.07, p > 0.1$ ). For the current study at least, we can rule out the possibility that decreased grip force values result from reduced movement velocities in the monocular viewing condition.

We note that the above dissociation between grip aperture scaling and grip force scaling is consistent with our previous finding that grip force scaling is affected by pictorial visual cues while grip aperture scaling is not [12]. In that case, we argued that the primary task of the visuomotor mechanisms underlying hand kinematics was to determine where to position the digits on the target object so as to achieve a stable grasp. We suggested that this most likely involved an analysis of object size and shape, but need not necessarily require a complete description of the object. In contrast, object knowledge would appear to be critical to the anticipatory control of grip force [13]. This account is also broadly consistent with the proposals of Goodale and colleagues [3, 6, 7] that the scaling of grip aperture is ordinarily carried out by visuomotor mechanisms within the dorsal visual processing stream that are particularly dependent upon binocular visual cues. However, in the absence of such cues, neurologically intact individuals can make use of perceptual mechanisms, specifically pictorial visual cues, to compute estimates of movement amplitude and object size from the uncalibrated retinal image. Unfortunately, such cues appear to be far from

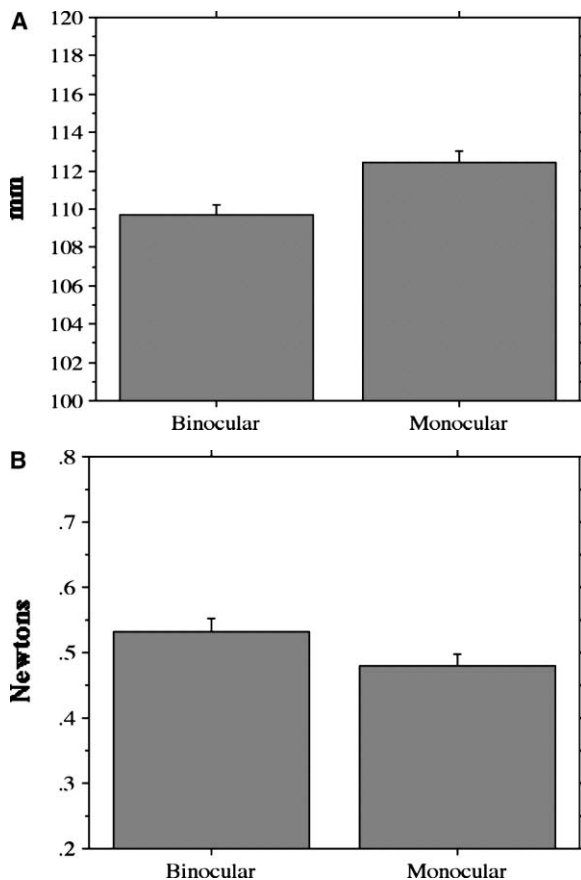

Figure 2. Means for Peak Grip Aperture and Peak Grip Force  
(A) Mean peak grip aperture for objects presented under binocular and monocular viewing conditions. Wider grip apertures were observed when participants grasped objects under monocular viewing conditions.  
(B) Mean peak grip force for objects presented under binocular and monocular viewing conditions. The graph confirms that significantly less grip force was exerted by subjects when lifting objects under monocular viewing conditions.

optimal and result in a consistent underestimation of object size.

In conclusion, previous studies that have investigated the effects on reach-to-grasp movements of removing binocular vision have yielded conflicting results. By one account, monocular vision results in impairments to size-constancy mechanisms and produces, as a consequence, underestimates of target distance and object size. By a second account, removal of binocular visual cues leads to increased visuomotor uncertainty and produces strategic changes in visuomotor safety margins. In the current study, we demonstrate that evidence consistent with each of these accounts can be observed within a single study.

#### Experimental Procedures

A total of 11 participants (7 females and 4 males) were recruited from the University of Wales, Bangor, School of Psychology's Community Research Participant Panel. Their average age was 27.3 (SD = 5.5) years. Participants were paid a small honorarium for their participation. All participants gave their informed consent before the experiment. All were right handed (determined by Edinburgh Handedness Inventory [adapted from Oldfield 1971]) and had normal or corrected-to-normal vision. Seven participants were assessed to be right-eye dominant, the remaining four were assessed to be left-eye dominant. All participants had stereoscopic vision in the normal range, with assessed stereoacuties of 50 s of arc or better, as determined by the Randot Stereotest (Stereo Optical).

Participants were tested on 4 blocks of 40 trials. Each block consisted of two trials of each of the possible location  $\times$  orientation combinations presented in a random order (Figure 1). Subjects performed two of the blocks under binocular viewing conditions and two blocks under monocular viewing conditions. Hand movements were recorded at a sampling rate of 60 Hz using a MacReflex 3D infrared motion analysis system. Three 5 mm  $\times$  5 mm reflective markers were placed on the distal portion of the thumb nail, on the distal portion of the index finger, and on the wrist, respectively. An additional marker was fixed to the target object. The 3D spatial coordinates of these markers were analyzed offline (see [9] for a more detailed description). Grip force data (Novatech model F250) were acquired at a sampling rate of 200 Hz from within MacReflex 3.2 software using Biopac data acquisition hardware (DA100A amplifier). Data were analyzed offline using analysis programs written within the LabVIEW programming environment (National Instruments). Raw data were low-pass filtered using a fourth-order Butterworth filter (cutoff frequency of 10 Hz).

#### Dependent Measures

Subjects were instructed to reach out and pick up the target objects, removing it from the table surface to a height of approximately 9 in, hold it in position for 1 s, and then return it to the table surface. Movement onset was defined as the first frame in which the wrist marker exceeded a velocity (in the direction of movement) of 2.5 cm/s. Movement end point was defined as the first frame in which the 3D displacement of the target marker was detected. Movement time (MT) was defined as movement end point minus movement onset. The following dependent measures were computed from the 3D coordinates of the wrist marker: peak velocity in the direction of movement (PV), time taken to reach peak velocity (TTPV), the time from movement onset to the time peak velocity in the direction of movement was achieved, and the percentage of the movement time spent in the deceleration phase (the time after PV to movement end point expressed as a percentage of the total movement time, %DP). The maximum grip aperture between the index finger and thumb was computed from the 3D coordinates for the markers placed on the thumb and index finger (MGA). Grip force onset was defined as the point at which the grip force, measured over three consecutive samples, exceeded a threshold of 0.1 N. The end of each trial was taken to be the beginning of the unloading phase, defined as the point at which grip force begins to decrease and

does not subsequently increase again. Peak grip force was defined as the maximum value detected during the period from grip force onset to the beginning of the unloading phase (MGF).

#### Acknowledgments

This work was supported by a grant from the Wellcome Trust awarded to S.R.J.

Received: November 7, 2001

Revised: November 19, 2001

Accepted: December 4, 2001

Published: February 5, 2002

#### References

1. Goodale, M.A., and Milner, A.D. (1992). Separate visual pathways for perception and action. *Trends Neurosci.* 15, 20–25.
2. Goodale, M.A. (1993). Visual pathways supporting perception and action in the primate cerebral cortex. *Curr. Opin. Neurobiol.* 3, 578–585.
3. Milner, A.D., and Goodale, M.A. (1995). *The Visual Brain in Action* (Oxford: Oxford University Press).
4. Shikata, E., Tanaka, Y., Nakamura, H., Taira, M., and Sakata, H. (1996). Selectivity of the parietal visual neurones in 3D orientation of surface of stereoscopic stimuli. *Neuroreport* 7, 2389–2394.
5. Dijkerman, H.C., Milner, A.D., and Carey, D.P. (1996). The perception and prehension of objects oriented in the depth plane. I. Effects of visual form agnosia. *Exp. Brain Res.* 112, 442–451.
6. Marotta, J.J., Behrmann, M., and Goodale, M.A. (1997). The removal of binocular cues disrupts the calibration of grasping in patients with visual form agnosia. *Exp. Brain Res.* 116, 113–121.
7. Servos, P., Goodale, M.A., and Jakobson, L.S. (1992). The role of binocular vision in prehension: a kinematic analysis. *Vision Res.* 32, 1513–1521.
8. Servos, P., and Goodale, M.A. (1994). Binocular vision and the on-line control of human prehension. *Exp. Brain Res.* 98, 119–127.
9. Jackson, S.R., Jones, C.A., Pritchard, C., and Newport, R. (1997). A kinematic analysis of goal-directed prehension movements executed under binocular, monocular, and memory-guided viewing conditions. *Vis. Cognition* 4, 113–142.
10. Mon-Williams, M., and Dijkerman, H.C. (1999). The use of vergence information in the programming of prehension. *Exp. Brain Res.* 128, 578–582.
11. Watt, S.J., and Bradshaw, M.F. (2000). Binocular cues are important in controlling the grasp but not the reach in natural prehension movements. *Neuropsychologia* 38, 1473–1481.
12. Jackson, S.R., and Shaw, A. (2000). The Ponzo Illusion affects grip-force but not grip-aperture scaling during prehension movements. *J. Exp. Psychol. Hum. Percept. Perform.* 26, 418–423.
13. Johansson, R.S., and Cole, K.J. (1992). Sensory-motor coordination during grasping and manipulative actions. *Curr. Opin. Neurobiol.* 2, 815–823.
14. Shaw, A., Jackson, S.R., Harvey, M., Newport, R., Kramer, T., and Dow, L. (1997). Grip force scaling after hemispatial neglect. *Neuroreport* 8, 3837–3840.